

ACCESSORIES for ROTARY ENCODERS

COUPLING

● Dimensions (mm)

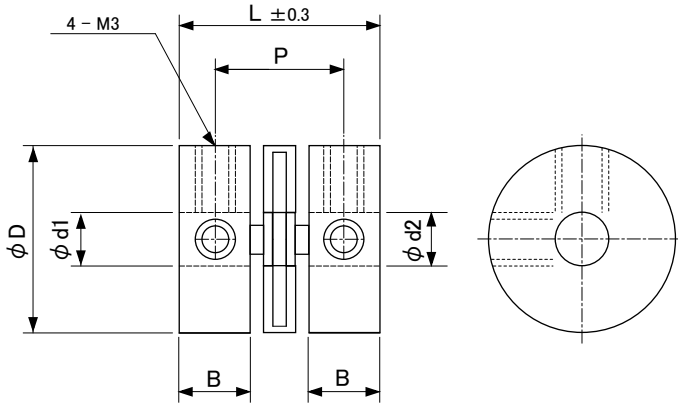

Model	d1	d2	D	L	P	B
C-44	4	4	14	15	9.5	5
C-46	4	6	15	16	9.8	5.5
C-55	5	5	14	15	9.8	5.2
C-56	5	6	15	16	9.8	5.5
C-66	6	6	15	16	9.8	5.5
C-68	6	8	18	18	13	5.5
C-88	8	8	18	18	13	5.5

※ Please confirm the diameter of the rotating shaft and the diameter of the encoder's shaft.

● Specification

Model	Rated Torque	Curved Angle of Shaft	Setting Screw	Torque for Screw	Material	Color	Weight
C-44	0.5 Nm	5° max	M3 x 4 4pcs	200m Nm	Polyacetal	Black	2.4g
C-46	0.7 Nm						3.0g
C-55	0.7 Nm						2.7g
C-56	0.7 Nm						3.0g
C-66	0.8 Nm						4.0g
C-68	1.0 Nm						
C-88	1.0 Nm	M3 x 5 4pcs	250m Nm	Glass Fiber Reinforced PBT			

※Temp.Range : -20 ~ +60°C

MOUNTING BRACKET

※Bracket is not used for CB Series. B-15 only used for CE Series.

● Dimensions (mm)

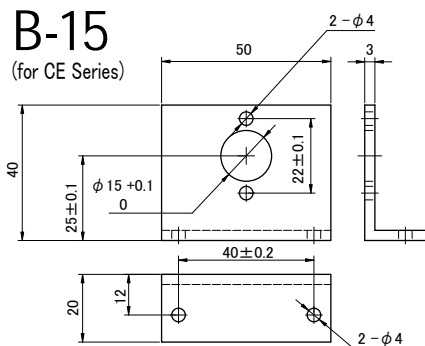
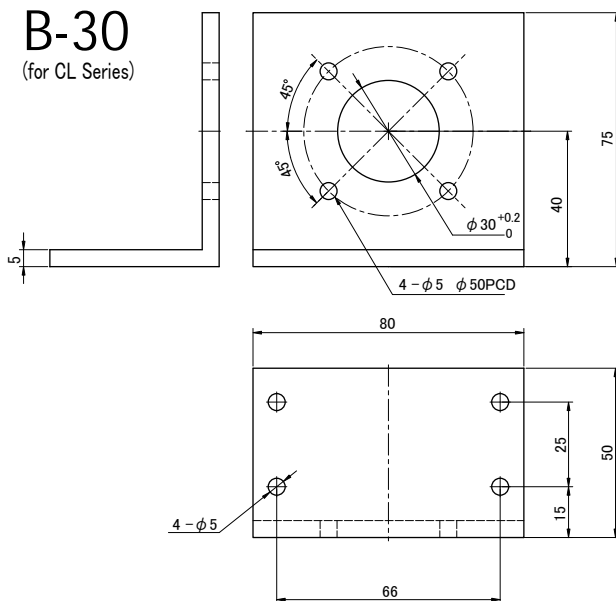

● Material : Aluminum

● Installation Method

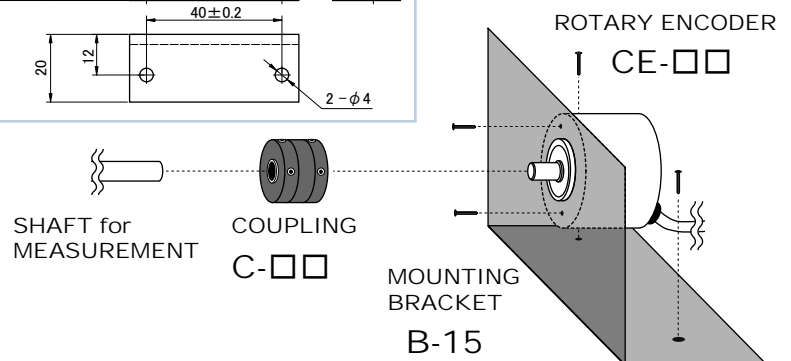

This catalog is last revised on July 15, 2010.
Specifications are subject to change without prior notice.
All Rights Reserved, Copyright © 2010, LINE SEIKI CO., LTD.



LINE SEIKI CO., LTD.

Address * : *37-7 Chuo-cho, 2-Chome Meguro-ku, Tokyo 152-0001 Japan
Contact * : *Tel : +81-3-37165151 * Fax : +81-3-37104552
E-mail * : *webtrade@line.co.jp * Web : http://www.line-seiki.com